

The thrust cylinders are linear actuators, designed for a high force to size ratio. This makes the cylinder ideal to use for clamping, riveting, punching and similar applications where a high force is required.

- Thrust cylinders provide large forces
- Compact dimensions
- C0D, diaphragm type
- C0P, piston type
- Available in single and double acting versions



Operating information

Working pressure: Max 8 bar
Working temperature: -20°C to +70°C

Stainless steel piston rod
Piston rod according to ISO 4395



Compressed air cylinders, types C0D and C0P should not be used in vertical applications without external stop.

For more information see www.parker.com/euro_pneumatic

C0D - Double acting

Force at 6 bar, N	Port size	Stroke mm	Order code
3000	G1/4	40	C0D300-40
6000	G1/4	50	C0D600-50
12000	G1/2	50	C0D1200-50
25000	G1/2	60	C0P2500-60
25000	G1/2	80	C0P2500-80

C0P - Single acting

Force at 6 bar, N	Spring N force		Port size	Stroke mm	Order code
	Max N	Min N			
1600	314	128	G1/4	50	C0P160-50S
1600	314	128	G1/4	80	C0P160-80S
3000	314	128	G1/4	50	C0P300-50S
3000	314	128	G1/4	80	C0P300-80S
3000	294	98	G1/4	40	C0D300-40S
6000	638	98	G1/4	50	C0D600-50S
12000	981	235	G1/2	50	C0D1200-50S
25000	2700	883	G1/2	60	C0P2500-60S
25000	2700	883	G1/2	100	C0P2500-100S

The spring forces in single acting cylinders are sufficient to return the piston rod without load

Accessories

Neck mounting nut

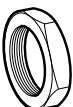
Lock nut thread	For cylinder	Order code
 M24x2	C0D300	9141100000
M36x3	C0D600/1200	9141100100
M48x3	C0P2500	9141100200
M24x3	C0P160/300	9141100300

Piston rod nut (one nut is included)

Piston rod nut thread	For cylinder	Order code
 M12	C0P160/300 and C0D300	0266211200
M16	C0D600	0266211400
M20	C0D1200	0266211600
M24	C0P2500	0266211800

Dimensions (mm), piston type

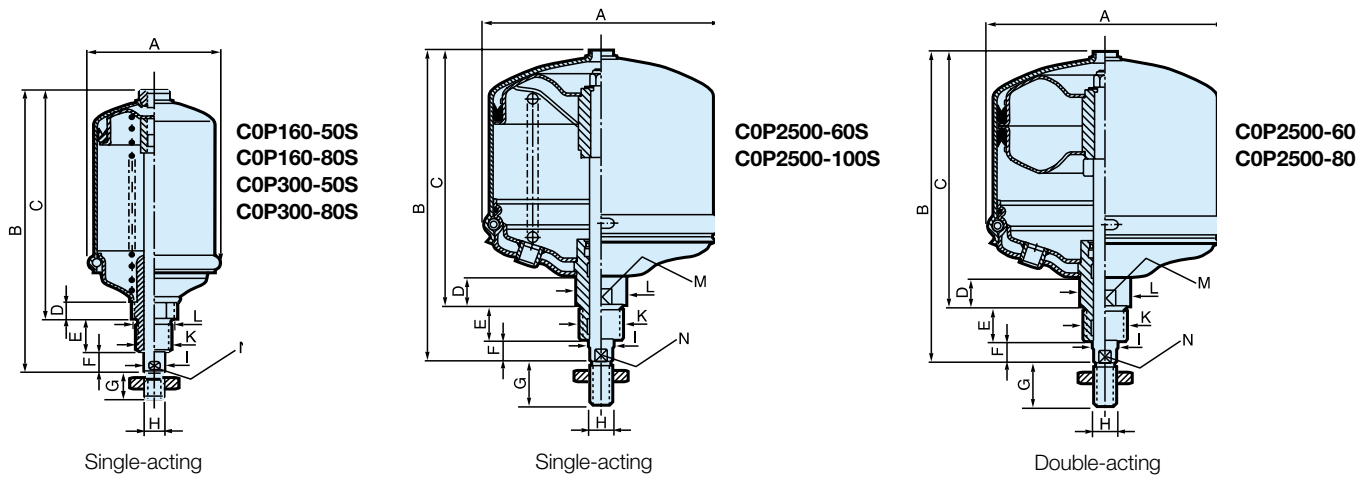

Type	Connection thread	A	B	C	D	E	F	G	H	I Ø	K	L Ø	M	N
C0P160-50S	G1/4	66	192	151	18	30	11	24	M12x1,75	14	M24x3	30	30	12
C0P160-80S	G1/4	66	222	181	18	30	11	24	M12x1,75	14	M24x3	30	30	12
C0P300-50S	G1/4	93	192	151	18	30	11	24	M12x1,75	14	M24x3	30	30	12
C0P300-80S	G1/4	93	222	181	18	30	11	24	M12x1,75	14	M24x3	30	30	12
C0P2500-60S	G1/2	268	345	285	33	40	20	48	M24x3	28	M48x3	56	50	25
C0P2500-100S	G1/2	268	385	325	33	40	20	48	M24x3	28	M48x3	56	50	25
C0P2500-60	G1/2	268	345	285	33	40	20	48	M24x3	28	M48x3	56	50	25
C0P2500-80	G1/2	268	385	325	33	40	20	48	M24x3	28	M48x3	56	50	25

Dimensions (mm), diaphragm type

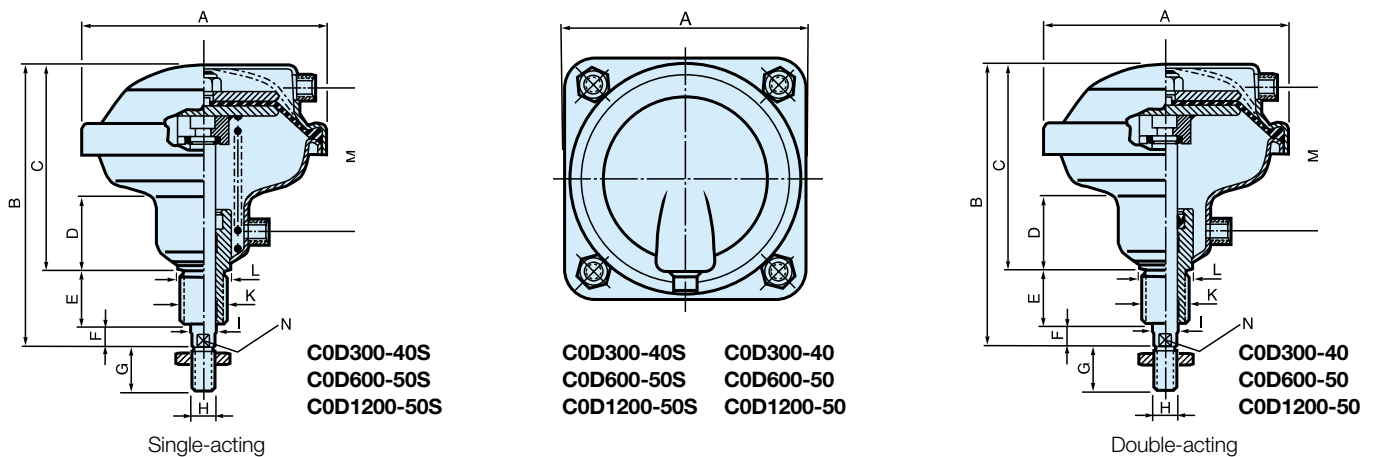

Type	Connection thread	A	B	C	D	E	F	G	H	I Ø	K	L Ø	M	N
C0D300-40S	G1/4	150	183	131	48	38	14	24	M12x1,75	16	M24x2	30	90	13
C0D300-40	G1/4	150	183	131	48	38	14	24	M12x1,75	16	M24x2	30	90	13
C0D600-50S	G1/4	195	212	154	55	38	20	32	M16x2	20	M36x3	43	107	17
C0D600-50	G1/4	195	212	154	55	38	20	32	M16x2	20	M36x3	43	107	17
C0D1200-50S	G1/2	261	243	178	58	45	20	40	M20x2,5	25	M36x3	43	117	22
C0D1200-50	G1/2	261	243	178	58	45	20	40	M20x2,5	25	M36x3	43	117	22

Press stand for thrust cylinders

A simple press for efficient mounting and pressing can easily be built by screwing the thrust cylinders into the threaded holes in the very stable and strong steel press stand. The stand is available in two versions with different fastening threads for the cylinders.

The top plate has two different threads, and can be rotated through 180 degrees to present the correct thread for nose fitting of the cylinders.

The sub-base is fitted with a T-track for easy mounting of accessories. It also has two through holes for simple and secure fitting to a work bench.



NOTE! Remember that an approved two-handed press control must be used with the cylinders and the press stand to prevent crush injuries. We recommend the use of our type PXP two-handed press control. It is available in a number of versions, and is simple, ergonomic and safe to incorporate in the press stand. It meets the requirements of safety standards EN574 and EN954-1.

For more information, see our website:
www.parker.com/euro_pneumatic

Description	Threads A/B	Weight kg	Order No.
Press stand for C0P160 / C0P300 / C0D300	M24x2/M24x3	24	C0P-C0D-P01
Press stand for C0D600 / C0D1200 / C0P2500	M36x3/M48x3	24	C0P-C0D-P02

Dimensions

